

834H

Wheel Dozer



Engine

Engine Model	Cat [®] C18 with ACERT [®] Technology	
Gross Power	413 kW	554 hp
Flywheel Power	372 kW	498 hp

Weights

Operating Weight	47 106 kg	103,849 lb
------------------	-----------	------------

Blade Specifications

Blade Capacities	7.9 m ³ –22.2 m ³	10.33 yd ³ –29 yd ³
------------------	---	---

834H Wheel Dozer

Purpose built structures and a strong power train combine to make the Cat 834H a workhorse for all your dozing needs.

Power Train

- ✓ The 834H uses the Cat C18 engine with ACERT[®] Technology that is U.S. EPA Tier 3/EU Stage III compliant. Smooth consistent shifting with fingertip control and electronic controls contribute to increased levels of productivity. **pg. 4**

Hydraulics

- ✓ The 834H uses electro-hydraulics for ease of operation and operator comfort. The new Automatic Blade Positioning helps to improve machine productivity. **pg. 6**

Structures

- ✓ The 834H has a purpose built front frame for shocks and twisting forces that a wheel dozer will encounter in daily work. Structure improvements include larger diameter pin and bearings in the lower high hitch and high strength steel in the hitch bosses. **pg. 8**

Customer Support

Your Cat dealer can provide you with the services needed to keep your Cat machines up and running. **pg. 13**

The Cat 834H Wheel Dozer continues the Caterpillar[®] tradition with its power, mobility, operator comfort and blade selection that allows you to get the job done quickly and economically. The 834H is ideally suited for the rugged duties associated with mining, quarries and utilities.



Blades

- ✓ On the 834H, you can choose from the straight blade, universal blade, coal blade or the new semi-universal blade to allow for maximum productivity from your wheel dozer. **pg. 9**

Operator Station

- ✓ The 834H provides improvement in blade control with the control pod change integrating the tilt/tip switch into the joystick to help increase productivity. The Automatic Blade Positioning switch is also conveniently located. **pg. 10**

Serviceability

- ✓ The 834H has most of its daily check points on the left side to allow quicker walkaround inspections. Service has been improved with new, remote pressure taps for the transmission. **pg. 12**



✓ *New Feature*

Power Train

The 834H power train components deliver dependable, reliable performance customers expect from Cat Wheel Dozers.



Cat C18 Engine with ACERT® Technology.

The Cat C18 engine is an increased displacement version of the proven Cat 3456 engine. The C18 is U.S. EPA Tier 3/EU Stage III emissions compliant and features a 3.5 percent horsepower increase over the previous 3456. The C18 uses ADEM™ IV (Advanced Diesel Engine Management) engine controller to manage fuel delivery and valve timing, as well as all other engine systems.

Net Torque Rise. Torque converter torque rise is 36 percent in drive net and 37 percent in direct drive. The torque curve effectively matches the transmission shift points to provide maximum efficiency and faster cycle times.

Starting System. The 834H uses a 100-amp alternator and four 12-volt 360 amp-hour batteries with a total of 1,000 cold cranking amps.

Mechanically Actuated Electronic Fuel Injection (MEUI™). MEUI is a unique system that combines the technical advancement of an electronic control system with the simplicity of direct mechanically controlled unit fuel injection. The MEUI system is able to control injection pressure over the entire engine operating range. These features allow the C18 to have complete control over injection timing, duration and pressure.

Air Cleaners. The 834H uses larger air cleaners than the 834G.

ADEM™ IV (Advanced Diesel Engine Management). ADEM IV uses a 32-bit computer with sensors through the engine to regulate fuel delivery, valve timing and all other engine systems that require input to manage load and performance.

Air-to-Air Aftercooler (ATAAC) System. The ATAAC system provides a separate cooling system for the intake manifold air. It routes hot, compressed air from the turbo and cools it with a single pass, air-to-air aluminum heat exchanger. The cooled, compressed air greatly reduces the emissions produced, meeting U.S. EPA Tier 3/EU Stage III requirements.

- Airflow matched turbocharger with power rating helps reduce emissions.
- 19 percent more bearing area allows the engine to operate at the maximum cylinder pressure.

- Higher cylinder pressure capability helps reduce fuel consumption and improve high altitude operation.
- Cylinder heat exhaust port sleeves reduce heat rejection which results in less heat transfer into the water jacket system.

Separate Engine Cooling System.

The radiator and fan are isolated from the engine compartment for more efficient cooling which allows a sloped hood that provides an improved viewing area.

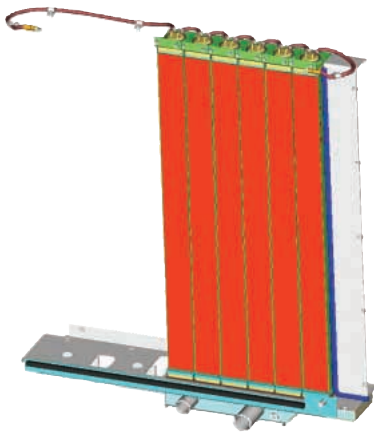

Next Generation Modular Radiator (NGMR).

The parallel flow system, with six cores standard, improves cooling capabilities. Serviceability is enhanced as there is no top tank to remove. The NGMR uses copper brazed brass tubes and copper fins.

Electronically Controlled, Planetary Power Shift Transmission.

The Cat transmission features perimeter-mounted, large diameter clutch packs and control inertia for smooth shifting and increased component life. It can be recalibrated using the Cat Electronic Technician (ET) service tool.

Parking Brake. The spring-applied, oil released and dry disc parking brake is mounted on the transfer heat output shaft. Manual override is possible to allow movement of the machine.

Impeller Clutch Torque Converter (ICTC).

Combined with the Rimpull Control System (RCS), the ICTC allows the operator maximum flexibility in modulating rimpull.

- The torque converter is equipped with a standard lock-up clutch for direct drive efficiency.
- The ICTC offers the ability to compensate for wear by recalibration for optimum left pedal modulation regardless of torque converter wear.
- The operator can reduce rimpull to 20 percent while maintaining high engine speed for slower work without losing power by using the left pedal. After 20 percent, further pedal travel applies the brake.
- The RCS allows the operator to select from four preset rimpull settings (low, medium, high and maximum).

Heavy Duty Axles. Optional axle oil coolers, permanently lubed universal joints and stronger axle components in both the differential and final drives are offered for increased performance, serviceability and durability. The conventional differential is standard.

Final Drives. The final drives feature planetary reduction at each wheel. Torque is developed at the wheel which provides less stress at the axle shafts. The planetary units are oil-bath lubricated and can be removed independently from the wheels and brakes. Ring gears are splined to the axle housing. Proprietary gear cutting and heat treating methods are used in the manufacturing and bronze thrust washers interface with the sun gear/bearing retainer.

Free-Floating Axle Shafts. The free-floating axle shafts can be removed independently of the wheels and planetaries for quick and easy serviceability.

Optional Axle Oil Cooling System.

The axle oil cooling system has been redesigned to make it a more reliable and robust system. The fan motor is now driven by separate 10W oil source instead of the oil from the axle.

Axle Shaft, Oil Disc Brakes. These brakes are adjustment-free, fully hydraulic and completely sealed. Disc face grooves provide cooling, even when brakes are applied for a long, fade-resistant service life.

Service Brakes. Four wheel, hydraulic, oil dipped multiple disc service brakes are adjustment-free, completely enclosed and allow modulated engagement without slack adjusters.

Secondary Brakes. The secondary brakes are fully modulated. The front and rear service brake circuits are isolated so one circuit can operate if pressure drops in the other circuit.

Cat Engine Compression Brake.

The heavy-duty compression brake supplies engine braking torque by opening the exhaust valves during the compression stroke of the engine. It provides 25 percent more braking power in the recommended operating range when compared to previous systems.

Hydraulics

Well-balanced hydraulics offer precise, low-effort control and trouble-free operation.



Electro-Hydraulic Control System.

Hydraulic efficiency is increased and operator comfort is enhanced through the low-effort fingertip controls. XT-3™ and XT-5™ hose combine with reliable components to help reduce the risk of leaks and blown lines.

Blade Control. A floor-mounted, single lever, fingertip control for lift/lower/tilt/tip sends electronic signals to a main hydraulic valve positioned outside the cab. This eliminates sound, heat and control effort associated with the in-cab hydraulic valve systems. The tilt/tip switch has been moved to the joystick for ease of operation because the operator does not have to remove his hand from the joystick to adjust the tilt or tip.



Automatic Blade Positioning (ABP).

This patented system is intended to lower fatigue, increase comfort and help make the operators more productive. It mimics manual operations by automatically lowering the blade when the machine is shifted forward and raising it in reverse. The set points to where the blade raises/lowers can be easily adjusted from the operator's seat.

Additionally, a “kick-out” feature allows the operator to raise/lower the blade without having to hold the joystick in place. The operator always maintains full control of the blade during this cycle with the ability to override ABP.

Tilt/Tip Circuit. Fingertip control allows for easy operation of the tilt/tip circuit. Lift circuit features:

- Four positions – raise, hold, lower and float
- Detente hold on float

Case Drain Filtration. The 834H has two case drain filters that protect the steering and fan pumps from contamination with easy access for service.

Load Sensing Steering. The STIC control system integrates the steering and transmission into a single controller. The steering system utilizes a variable displacement pump for maximum machine performance by directing power through the steering system only when needed.

Caterpillar Monitoring System (EMS-III). EMS-III continually monitors various machine systems through three instrument clusters and provides a three-level warning system to alert the operator of immediate or pending problems. It shares information with the engine, hydraulic and transmission controls that can be used during servicing to simplify service and troubleshooting. The Caterpillar Monitoring System allows for new software to be uploaded in the cab.

Demand Fan. The speed controlled, hydraulic demand fan provides maximum cooling efficiency by directing the appropriate amount of power through the fan system based on the coolant temperature.

Structures

Advanced design and materials provide superior strength to the purpose built structures.

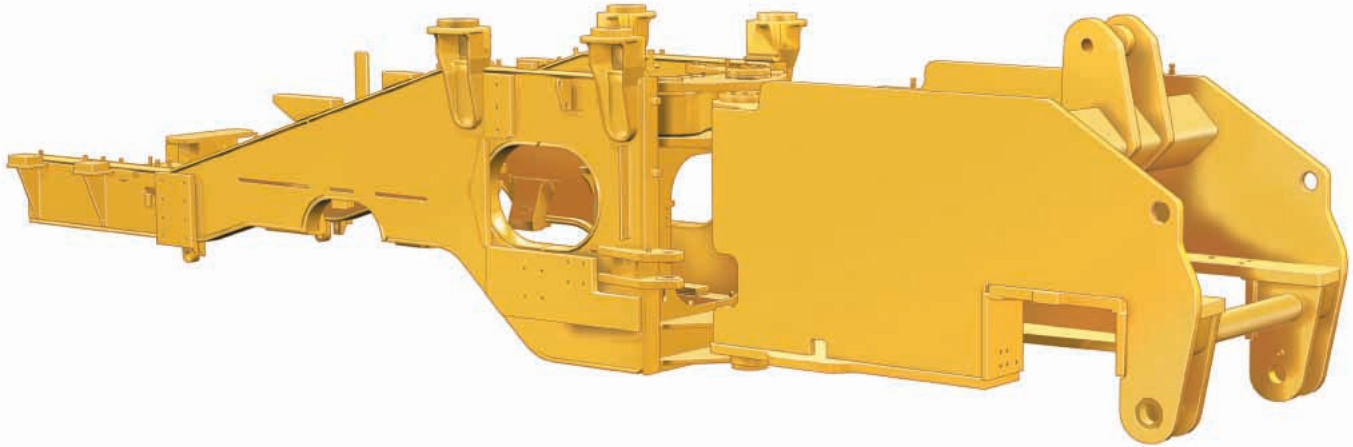

Structure Construction. Combining the use of robotic welding on up to 90 percent of the 834H with castings used in several areas contributes to increased strength by helping spread the load and reducing the number of parts. This provides highly consistent welds with deep plate penetration and excellent plate fusion. The benefit is increased durability and fatigue strength. The computer controlled machining ensures the alignment of pin bore, axle pad, cab mount and transmission/engine components.

Box Section Engine End Frame Structures. Designed to resist twisting and torsional forces, the box section engine end frame provides a solid foundation for the axles, engine and transmission.

Two Plate Front Frame. The two plate front frame design provides maximum structural strength during dozing applications for improved stability.

Spread Hitch Design. The spread hitch design improves load distribution by reducing loads to the hitch bearings. The large center hitch design improves hydraulic line routing and makes service access easier.

Upper and Lower Hitch Pins. The hitch pins pivot on double-tapered roller bearings. Box-style sections in the hitch pins and crossmember assembly improve frame structure strength. Increased diameter lower hitch pins add to the robust design.

Engine and Transmission Mounts. A rubber isolation mount design reduces noise and vibration.

Blades

Cat blades are available to match many dozing requirements.



Cat Blades. Cat blades are resilient, durable and designed with excellent dozing and rolling characteristics.

- Capacities and widths are set to achieve increased productivity.
- Spreading design allows for spreading of cover material, as well as dozing of heavier loads.



Straight Blade. The straight blade ($7.9 \text{ m}^3/10.33 \text{ yd}^3$) is designed for production dozing in stockpile material and general earthmoving.



Universal Blade. The universal blade ($11.1 \text{ m}^3/14.65 \text{ yd}^3$) is designed to move large loads over long distances in mining applications.

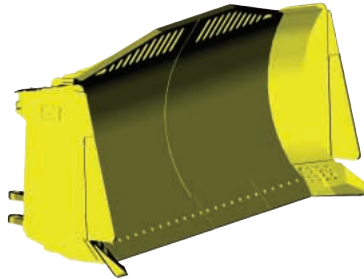

Semi-Universal Blade. The characteristics of the straight and universal blades are combined into the semi-universal blade ($10.1 \text{ m}^3/13.3 \text{ yd}^3$). It provides increased capacity with the addition of short wings which include only the dozer end bits without sacrificing spreading characteristics of straight blades.



Coal Blade. The coal blade ($22.2 \text{ m}^3/29 \text{ yd}^3$) is designed for precise and productive dozing while helping to retain load control with increased capacity for lighter materials. Wing angles help retain the load while dozing. This blade is available from Cat Work Tool and Services (CWTS).

Assemblies. The straight, semi-universal and universal blades consists of the blade, push arms, hydraulic lift, tip and tilt cylinders, trunnion mounting, stabilizer and hydraulic line guards.

Other Available Options. See your Cat dealer for blade options such as coal and wood scoop from CWTS and Custom Products.

Operator Station

Ergonomically designed cab for operator comfort with low-effort controls helps increase efficiency and productivity.



World Class Cab. Over 3.18 m³ (112 ft³) of volume incorporates innovations for operator comfort, maneuverability and productivity. Features include outstanding viewing area, cab ventilation with interior sound levels below 77 dB(A), a coat hook, cup holder, storage bin, room for a large lunch cooler and intermittent wet-arm wipers. It is also radio-ready.

1 STIC System. The STIC controller combines gear selection into one lever that requires less effort and provides smooth shifting. Side-to-side motions for steering, finger operated direction control and thumb operated buttons for gear selection combine to provide a fluid motion that reduces effort and allows the operator to work the machine for long periods of time with little or no fatigue.

2 Left Pedal. The ICTC is operated by the left pedal. Within the first 39 mm (1.5 in) of pedal travel, rimpull can be controlled from 100 percent to 20 percent. Fully depressing the pedal applies the brake. The right pedal allows standard braking.

3 Comfort Series Seat. With an air suspension and retractable seat belt, the Comfort Series seat is designed for comfort and support. Seat cushions reduce pressure on the lower back and thighs while allowing increased arm and leg movement.

4 Electro-Hydraulic Blade Controls.

The 834H integrates the tilt/tip switch to the joystick on the control pod. In addition, the 834H comes with the standard ABP system that allows the operator to preset the blade position for dozing and reversing at high speeds.

5 Tilt/Tip Switch. This switch has been fully integrated into the blade control joystick and allows the operator to have full control over the blade position.

6 Electro-Hydraulic Lock-out Switch.

This lock-out switch disables the hydraulic controls.

7 Automatic Blade Positioning.

The ABP system provides operator automation through the use of in-cylinder sensors and implement software. It contributes to operator comfort and improves productivity.

8 Caterpillar Monitoring System (EMS-III). EMS-III provides information on the 834H's major components and systems.

- Gauges display fuel tank level and temperatures for engine coolant, torque converter and hydraulic oils. The tachometer is an analog gauge with digital readout for gear selection and ground speed.
- The main module consists of 10 fault indicators and one display.
- System alerts the operator if the transmission is engaged while the parking brake is applied or if pressure drops, the brake is applied.

Throttle Lock. Similar to cruise control in an automobile, throttle lock allows the operator to preset engine speed for a variety of applications, resulting in faster cycle times and increased productivity.

Rimpull Control System. RCS has four factory preset rimpull settings (low, medium, high and maximum) to better match ground conditions.

Autoshift. With autoshift, the operator is able to set the maximum gear into which the transmission will be allowed to shift. This feature allows additional comfort and focus on the job. The switch also offers a manual position for operator controlled shifting.

Lock-up Clutch Torque Converter Switch.

The switch activates the lock-up clutch for direct drive efficiency.

Front and Rear Window Wiper/Washer.

Wiper/washer controls are within easy reach so the operator can maintain a clear field of vision.

9 Cat Engine Compression Brake.

This brake supplies engine braking torque by opening the exhaust valves fueling the engine compression stroke.

10 Viewing Area. The 834H has an excellent viewing area through the use of bonded glass in the front windshield. An internal ROPS improves peripheral viewing by eliminating the large structure outside the cab.

Serviceability

Simplified service means more production time.



Easy Maintenance. In addition to servicing features built into the engine, the 834H includes the following:

Rear Access Stairs and Standard Left-Hand Stairway. The standard left-hand stairs allow comfortable access for operators and service personnel.

Remote ECPC Pressure Taps. Easy to reach and access, the ECPC pressure taps are now located behind the cab, under the platform doors.

Service Platform. Passage to the hydraulic filters, pumps and transmission is available through a large door in the platform behind the cab.

Electronics Bay. A separate door in the platform provides access to the fuses and electronic control modules.

Batteries. Access for the batteries is provided through hinged doors in the bumper.

Caterpillar Monitoring System (EMS-III).

Provides operators and service technicians with diagnostic information on the machine's major components and systems. It also allows for a flashable software using a laptop and Cat ET instead of replacing a chip that contains new software.

Radiator Clean-out Doors. Easy access is provided to clean out the radiator area.

Grouped Lube Points. Lube points are grouped and labeled for easy daily service.

Sight Gauges. Quick fluid level checks for the transmission, hydraulic tanks and radiator are possible with sight gauges.

Ground Level Engine Shut-off.

Engine shut-off and electrical disconnect switches are standard.

Oil Change Interval. Caterpillar has maintained the 500-hour oil change interval on the 834H with the C18 engine with ACERT Technology.

Brakes. With axle-shaft design, the brakes can be serviced while leaving the final drive intact.

Cat Product Link. The 834H has the option of Product Link from the factory. It allows the customer to track the machine location and service hours through global position system (GPS) technology and provides all logged diagnostic codes.

Customer Support

Cat dealer services help keep your machine operating longer with lower costs.

Machine Selection. Make detailed comparisons of the machines under consideration before purchase. Cat dealers can estimate component life, preventive maintenance cost and the true cost of lost production.

Purchase. Look past initial price. Consider the financing options available as well as the day-to-day operating costs. Look at dealer services that can be included in the cost of the machine to yield lower equipment owning and operating costs over the long run.

Customer Support Agreements. Cat dealers offer a variety of product support agreements and work with you to develop a plan that best meets specific needs. These plans can cover the entire machine, including work tools, to help protect your investment.

Product Support. You will find nearly all parts at our dealer parts counter. Cat dealers use a world-wide computer network to find in-stock parts to minimize machine downtime. Save money with genuine Cat Remanufactured parts. You receive the same warranty and reliability as new products at a cost savings of 40-70 percent.

Operation. Improving operating techniques can boost profits. Your Cat dealer has training video tapes, literature, classes and other ideas to help increase your productivity.



Maintenance Services. More and more equipment buyers are planning for effective maintenance before buying equipment. Choose from your dealer's wide range of maintenance services at the time you purchase your new machine. Repair option programs guarantee the cost of repairs up front. Diagnostic programs such as S·O·SSM and Coolant Sampling and Technical Analysis help you avoid unscheduled repairs.

Replacement. Repair, rebuild or replace? Your Cat dealer can help you evaluate the costs involved so that you can make the right choice.

Engine

Engine Model	Cat C18 with ACERT® Technology	
Gross Power	413 kW	554 hp
Flywheel Power	372 kW	498 hp
Direct Drive Net Power – Caterpillar	349 kW	467 hp
Direct Drive Net Power – EEC 80/1269	349 kW	467 hp
Direct Drive Net Power – ISO 9249	349 kW	467 hp
Direct Drive Net Power – SAE J1349 (JAN90)	345 kW	463 hp
Converter Drive Net Power – Caterpillar	372 kW	498 hp
Converter Drive Net Power – EEC 80/1269	372 kW	498 hp
Converter Drive Net Power – ISO 9249	372 kW	498 hp
Converter Drive Net Power – SAE J1349 (JAN90)	368 kW	494 hp
Bore	145 mm	5.7 in
Stroke	183 mm	7.2 in
Displacement	18.1 L	1,104 in ³

- These ratings apply at 1,800 rpm when tested under the specific standard conditions for the specified standard.
- Power rating conditions based on standard air conditions at 25° C (77° F) and 99 kPa (29.32 in Hg) dry barometer, using 35° API gravity fuel having an LHV of 42 780 kJ/kg (18,390 Btu/lb) when used at 30° C (86° F) [reference a fuel density of 838.9 g/L (7.001 lb/gal)].
- Net power advertised is the power available (at the flywheel) when the engine is equipped with the air cleaner, muffler, alternator and hydraulic fan drive.
- No derating required up to 3050 m (10,000 ft) altitude.
- Engine is U.S. EPA Tier 3/EU Stage III emissions compliant.

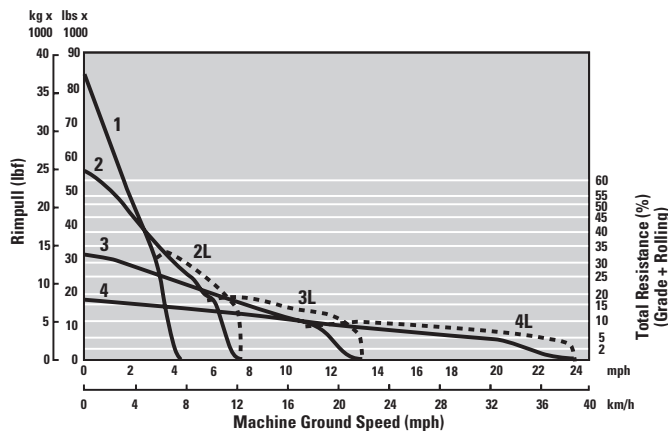

Transmission

Number of Forward Speeds	4	
Number of Reverse Speeds	3	
Converter Drive – Forward 1	6.8 kph	4.2 mph
Converter Drive – Forward 2	11.6 kph	7.2 mph
Converter Drive – Forward 3	20.3 kph	12.6 mph
Converter Drive – Forward 4	35.4 kph	22 mph
Converter Drive – Reverse 1	6.8 kph	4.2 mph
Converter Drive – Reverse 2	12.2 kph	7.6 mph
Converter Drive – Reverse 3	21.4 kph	13.3 mph
Direct Drive – Forward 1	Lock-up Disabled	
Direct Drive – Forward 2	12.4 kph	7.7 mph
Direct Drive – Forward 3	22.1 kph	13.7 mph
Direct Drive – Forward 4	38.5 kph	23.9 mph
Direct Drive – Reverse 1	7.2 kph	4.5 mph
Direct Drive – Reverse 2	13 kph	8.1 mph
Direct Drive – Reverse 3	23 kph	14.3 mph

- Travel speeds based on two percent rolling resistance and 35/65-33 L-4 tires.

Hydraulic System

Lift cylinder, bore and stroke	139.75 mm × 1021 mm (5.5 in × 40.2 in)	
Steering cylinder, bore and stroke	114.3 mm × 740 mm (4.5 in × 29.1 in)	
Right tilt and tip, bore and stroke	152.4 mm × 276 mm (6 in × 10.9 in)	
Left tilt and tip, bore and stroke	139.75 mm × 276 mm (5.5 in × 10.9 in)	
Relief valve setting	29 000 kPa	4,206 psi

Brakes

Brakes	Meet SAE/ISO 3450 1996
--------	------------------------

Axles

Front	Fixed
Rear	Oscillating $\pm 13^\circ$

Weights

Operating Weight	47 106 kg	103,849 lb
------------------	-----------	------------

Service Refill Capacities

Fuel Tank – standard	793 L	209.4 gal
Cooling system	94 L	24.8 gal
Crankcase	60 L	15.9 gal
Transmission	83 L	21.9 gal
Hydraulic tank	140 L	37 gal
Differentials and final drives – Front	186 L	49.1 gal
Differentials and final drives – Rear	186 L	49.1 gal

Cab

Cab	Integrated Rollover Protective Structure (ROPS)/Falling Object Protective Structure (FOPS) standard
Sound Performance Levels	Meets ANSI/SAE, SAE and ISO standards
ROPS/FOPS	Meet SAE and ISO standards

- Operator sound exposure Leq (equivalent sound pressure level) measured according to the work cycle procedures specified in ANSI/SAE J1166 OCT 98 is 77 dB(A) for the cab offered by Caterpillar when properly installed and maintained and tested with the doors and windows closed.
- Hearing protection may be needed when operating with an open operator station and cab (when not properly maintained or doors/windows open) for extended periods or in noisy environment.
- Exterior sound pressure level for the standard machine measured at a distance of 15 m (49.2 ft) according to the test procedures specified in SAE J898 JUN86, mid-gear-moving operation is 81 dB(A).
- Sound power level is 115 dB(A) measured according to the dynamic test procedure and conditions specified in ISO 6395:1988/Amd. 1:1996 for a standard machine configuration.
- For “CE” marked configurations, the labeled sound power level is 110 dB(A) measured according to the test procedures and conditions specified in 2000/14/EC.
- ROPS meets SAE J1394, SAE J1040 APR88, ISO 3471-1:1986 and ISO 3471:1994 standards.
- FOPS meets SAE J231 JAN81 and ISO 3449-1992 Level II standards.

Dimensions

All dimensions are approximate.

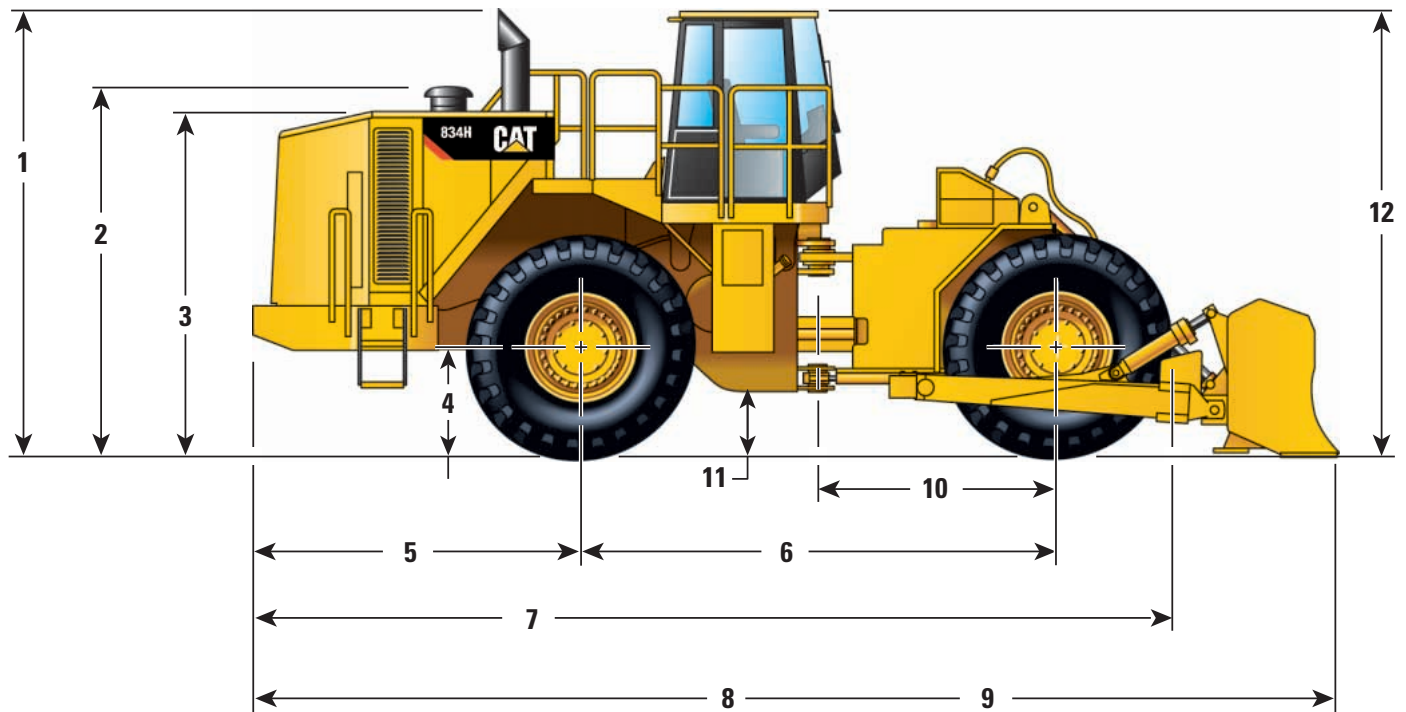

1	Height to Top of Exhaust Pipe	4104 mm	13.46 ft
2	Height to Top of Air Cleaner	3375 mm	11.07 ft
3	Height to Top of Hood	3146 mm	10.32 ft
4	Ground Clearance to Bumper	970 mm	3.18 ft
5	Center Line of Rear Axle to Edge of Bumper	3132 mm	10.28 ft
6	Wheelbase	4550 mm	14.93 ft
7	Length to Front Tire	8657 mm	28.4 ft

8	Length with Straight Blade on Ground	9883 mm	32.42 ft
9	Length with Universal Blade on Ground	10 471 mm	34.35 ft
10	Center Line of Front Axle to Hitch	2275 mm	7.46 ft
11	Ground Clearance	531 mm	1.74 ft
12	Height to Top of Cab	4083 mm	13.4 ft

Blade Specifications

Blade Type	Capacity	Overall Width	Height	Digging Depth	Ground Clearance	Maximum Tilt	Weight	Total Operating Weight
Straight Blade	7.90 m ³ 10.33 yd ³	5074 mm 199.8 in	1461 mm 57.5 in	557 mm 21 in	1324 mm 52.1 in	1270 mm 50.0 in	3196 kg 7,047 lb	47 106 kg 103,849 lb
Universal Blade	11.13 m ³ 14.56 yd ³	5151 mm 202.8 in	1461 mm 57.5 in	527 mm 20.7 in	1338 mm 52.7 in	1270 mm 50.0 in	4554 kg 10,042 lb	48 464 kg 106,844 lb
Coal Blade	22.2 m ³ 29.0 yd ³	5677 mm 223.5 in	1956 mm 77.0 in	465 mm 18.3 in	1178 mm 46.4 in	1482 mm 58.3 in	4290 kg 9,450 lb	48 195 kg 106,252 lb
Semi-Universal	10.13 m ³ 13.25 yd ³	4688 mm 184.6 in	1779 mm 70.0 in	507 mm 20.0 in	1352 mm 53.2 in	1270 mm 50.0 in	3538 kg 7,800 lb	47 448 kg 104,605 lb

Standard Equipment

Standard equipment may vary. Consult your Caterpillar dealer for details.

ELECTRICAL

- Alarm, back-up
- Alternator (100-amp)
- Batteries, maintenance-free
- Deutsch terminal connectors
- Electrical system (24-volt)
- Lighting system, halogen (front and rear), access stairway
- Starter, electric (heavy-duty)
- Starting receptacle for emergency starts

OPERATOR ENVIRONMENT

- Air conditioner
- Cab, sound suppressed and pressurized
 - Internal four-post rollover protective structure (ROPS/FOPS), radio ready (entertainment) includes antenna, speakers and converter (12-volt, 15 amp), 12-volt power port, tinted glass
- Cigar lighter (12-volt, 15-amp) and ashtray
- Coat hook
- Electro-Hydraulic tilt, tip and Automatic Blade Positioning (ABP) controls
- Heater and defroster
- Horn, electric
- Light, cab (dome)
- Lock-up clutch disable switch
- Lunchbox and beverage holders
- Monitoring system (EMS-III)
 - Action alert system, three category
 - Instrumentation, gauges:
 - Engine coolant temperature
 - Fuel level
 - Hydraulic oil temperature
 - Speedometer/Tachometer
 - Transmission oil temperature
 - Instrumentation, warning indicators
 - Axle/brake oil temperature (front/rear)
 - Brake oil pressure
 - Electrical system, low voltage
 - Engine intake/combustion air temperature
 - Engine oil pressure
 - Engine overspeed
 - Fuel pressure
 - Hydraulic oil filter status
 - Parking brake status
 - Transmission filter status
- Mirrors, rearview (externally mounted)
- Rimpull select switch
- Seat, Comfort Series (cloth), air suspension

- Seat belt, retractable, 76 mm (3 in) wide
- STIC control system with steering lock
- Tilt and lift control system lock
- Transmission gear indicator
- Wet-arm wipers/washers (front and rear)
 - Intermittent front wiper

POWER TRAIN

- Brakes, full hydraulic, enclosed, wet-disc
 - Multiple disc service brakes
- Case drain filters
- Demand fan
- Engine, Cat C18 MEUI with ACERT[®] Technology, ATAAC, ADEM[™] IV controller
- Fuel priming pump (electric)
- Parking brake
- Precleaner, engine air intake
- Radiator, Next Generation Modular Radiator (NGMR)
- Separated cooling system
- Starting aid (ether) automatic
- Throttle lock
- Torque converter, impeller clutch with lockup control system and rimpull control system (switch and dial in cab)
- Transmission, planetary, autoshift (4F/3R)

OTHER STANDARD EQUIPMENT

- Auto Blade Positioner (ABP)
- Doors, service access (locking)
- Engine, crankcase, 500 hour interval with CH-4 oil
- Grouped Electronic Clutch Pressure Control, remote mounted pressure taps
- Hitch, drawbar with pin
- Hood, metallic with lockable service doors
- Hydraulic oil cooler
- Muffler (under hood)
- Oil sampling valves
- Stairway, left side (rear access)
- Steering, load sensing
- Vandalism protection caplocks
- Venturi stack

BULLDOZERS

Bulldozer is not included in standard equipment

TIRES, RIMS AND WHEELS

A tire must be selected from the mandatory attachments section – base machine price includes a tire allowance

ANTIFREEZE

Premixed 50 percent concentration of Extended Life Coolant with freeze protection to -34° C (-29° F)

Mandatory Attachments (select one from each group)

Mandatory equipment may vary. Consult your Caterpillar dealer for specifics.

	kg	lb
Electrical		
Lighting, standard	0	0
Lighting, directional	2	5
Lighting, HID	41	90
Lighting, HID and directional	45	99
Power Train		
Fuel Systems		
Fuel, standard	0	0
Fuel, fast fill, Shaw AREO	4	8
Fuel, heater	4	8
Fuel, heater and fast fill	7	16
Engine		
Engine, standard	0	0
Engine, Cat compression brake	4	8
Access Stairs and Fender Arrangement		
Stairway, standard	0	0
Stairway and fenders	312	687
Sound Suppression Arrangement		
No suppression arrangement	0	0
Sound suppression arrangement	93	206
Hydraulics		
Steering System		
Steering, standard	0	0
Steering, secondary	14	30

	kg	lb
Bulldozers		
Note: Contact CWTS for coal blade and scoop options		
Bulldozer Arrangement, no blade	4267	9,408
Bulldozer Arrangement, straight blade	7348	16,200
Bulldozer Arrangement, SU-blade	7805	17,210
Bulldozer Arrangement, U-blade	9251	20,394
Tires, Rims and Wheels		
Note: All tires are tubeless, include rims and come in sets of four		
Firestone		
35/65-33 24 PR FS L4	0	0
35/65-33 24 PR FS L5	557	1,228
Goodyear		
35/65-33 24 PR GY L4	-573	-1,264
35/65-33 24 PR GY L5	64	140
Michelin		
35/65R33 XLDD1 * MX L4	-750	-1,653
35/65R33 XLDD2 * MX L5	-103	-227
Omission of Tires		
Rims only	-4151	-9,152

Optional Equipment (with approximate change in operating weight)

Optional equipment may vary. Consult your Caterpillar dealer for specifics.

	kg	lb		kg	lb
Electrical			Starting Aids		
Lights, cab, auxiliary	4	9	Heater, engine coolant	2	4
Lights, warning beacon	5	11	Heater, 220-volt	1	3
Guards			Miscellaneous Attachments		
Guards, crankcase	53	117	Computer Aided Earthmoving System (CAES) ready	8	18
Guards, hydraulic tank	8	18	Oil change, high speed	4	8
Operator Environment			Precleaner, turbine/trash	14	30
Mirror, internal (panoramic)	5	10	Product Link	3	7
Visor, front	5	10	Antifreeze		
Wiper, intermittent	9	20	Coolant, -50° C (-58° F)	0	0
Power Train					
Differential, No-SPIN rear	5	10			
Cooler, axle oil	183	403			

834H Wheel Dozer

For more complete information on Cat products, dealer services,
and industry solutions, visit us on the web at www.cat.com

© 2007 Caterpillar
All Rights Reserved
Printed in U.S.A.

Materials and specifications are subject to change without notice.
Featured machines in photos may include additional equipment.
See your Caterpillar dealer for available options.

CAT, CATERPILLAR, their respective logos, ACERT, "Caterpillar Yellow" and the
POWER EDGE trade dress, as well as corporate and product identity used herein,
are trademarks of Caterpillar and may not be used without permission.

AEHQ5617-02 (9-07)

Replaces AEHQ5617-01

CATERPILLAR[®]