

# 735B

Articulated Truck



## Engine

Engine Model Tier 2/EU Stage II	Cat® C15 ACERT™	
Gross Power – SAE J1995	336 kW	450 hp
Net Power – ISO 14396	330 kW	442 hp

## Weights

Rated Payload	32.7 tonnes	36 tons
---------------	-------------	---------

## Body Capacities

Heaped SAE 2:1	19.7 m <sup>3</sup>	25.8 yd <sup>3</sup>
----------------	---------------------	----------------------



## New Features

**C15 Engine with ACERT™ Technology** meeting Tier 2/EU Stage II engine emission regulations

**Controlled Throttle Shift (CTS) Transmission**

**Automatic Traction Control (ATC)**

**Passenger grab handles**

**Floor-mounted accelerator pedal**

**Park brake switch – guarded by raised dash moldings**

**Dash dimmer switch**

**Headliner with radio mounting**

**Machine width position lamps**

**Electric hood switch mounted in-cab**

**External grab rail around cab roof**

**Improved fuse panel**

**Color Multi-Purpose Display (CMPD) incorporating the rearview camera screen and cycle counter**

**Machine Security System Tornado-ready (optional)**

**External roof-level work lights (optional)**

**Motorized heated mirrors (optional)**

## Contents

Engine with ACERT™ Technology .....	3
Transmission .....	4
Suspension and Automatic Traction Control (ATC) .....	5
Operator Comfort .....	6
Ease of Operation.....	7
Durability and Reliability .....	8
Product Link .....	9
Serviceability .....	10
Complete Customer Support.....	11
Safety .....	12
735B Articulated Truck Specifications .....	13
735B Standard Equipment .....	18
735B Optional Equipment.....	18
Notes.....	19



**The new Cat® 735B with 32.7 tonnes (36 tons) rated payload offers proven reliability and durability, high productivity, superior operator comfort and lower operating costs.**

**The spacious two-person cab with forward facing passenger seat and off road oil/nitrogen front suspension cylinders keep the operator comfortable through out the working day.**

**The true “on-the-go” Automatic Traction Control (ATC) system automatically modulates the correct level of Inter-Axle and Cross-Axle differential lock engagement which will improve cycle times and productivity. No operator interaction is required.**

**The strong, durable Cat ACERT™ engines with the Tier 2/Stage II exhaust emission solution and electronically controlled smooth shifting transmissions deliver high productivity with low fuel consumption. There are significant changes/improvements to the engine/transmission software that result in smoother gear changes.**

# Engine with ACERT™ Technology

Innovative technologies optimize performance.

## **ACERT Technology**

The Cat® C15 ACERT™ engine continues the evolutionary, incremental improvements that provide breakthrough engine technology built on systems and components developed by Caterpillar with proven reliability.

## **Fuel Delivery**

Multiple injection fuel delivery involves a high degree of precision. Precisely shaping the combustion cycle lowers combustion chamber temperatures, generating fewer emissions and optimizing fuel combustion. This translates into more work output for your fuel cost.

## **Advanced Diesel Engine Management (ADEM) A4 Engine Controller**

The ADEM A4 electronic control module manages fuel delivery to get the best performance per liter or gallon of fuel used. The engine management system provides flexible fuel mapping, allowing the engine to respond quickly to varying application needs. It tracks engine and machine conditions while keeping the engine operating at peak efficiency.

## **Wastegate Turbocharging**

Single wastegate turbocharging provides higher boost over a wide range, outstanding low end performance with improved peak torque and engine response.

## **Mechanically Actuated Electronic Unit Injection (MEUI)**

A highly evolved fuel system with a proven record of reliability in the field. It combines the technical advancement of an electronic control system with the simplicity of direct mechanically controlled unit fuel injection. It excels in its ability to control injection pressure over the entire engine operating speed range. These features allow the C15 to have complete control over injection timing, duration and pressure.

## **Air-to-Air Aftercooling (ATAAC)**

ATAAC keeps air intake temperatures down and, in concert with the tight tolerance combustion chamber components, maximizes fuel efficiency and minimizes emissions. Significant improvements in air flow are generated by a turbocharger, unique cross-flow head and a single overhead camshaft.





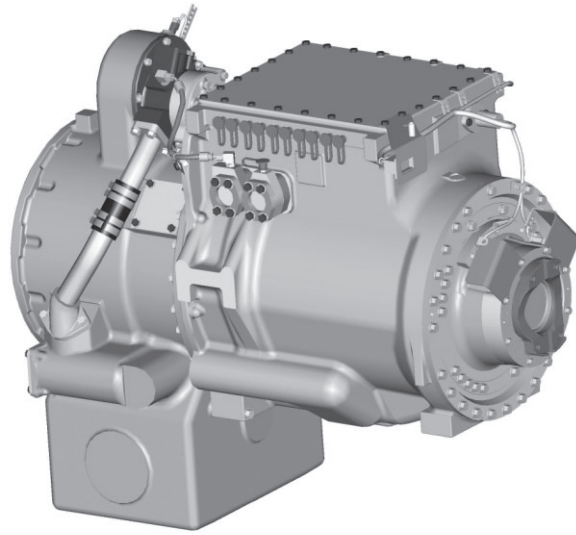

# Transmission

Proven Reliability.

## **Electronic Transmission**

The Cat seven-speed forward and two-speed reverse Electronic Clutch Pressure Controlled (ECPC) transmission features enhanced shift control logic with anti-hunt shift strategy for speed continuity, and to ensure constant shift times.

## **Min-max Governor Control**

ECPC control is matched to the min-max governor control for precise smooth shifting.

## **Two Reverse Gears**

The transmission arrangement provides a second reverse gear for improved performance when operating in longer rear hauling applications.

## **Smooth Transmission Gear Shifting – Shift Torque Management (STM)**

The 735B features ECPC Shift Torque Management (STM), with improved Shift Control Logic (SCL) and Part Throttle Shifting (PTS). These features allow smoother shifting and greater acceleration on grades while torque is maintained throughout the shift changes. SCL also provides automatic shift selection that is more specific to the desired machine operation, and downshifts when needed for maximum acceleration when increased throttle is applied. PTS allows shifting at lower speeds during part throttle operation, resulting in improved fuel economy, quieter machine operation, and better maneuvering in reduced speed operating conditions.

# Suspension and Automatic Traction Control (ATC)

## Performance and Productivity.

### Front Suspension

The three-point front suspension oscillates  $\pm 6^\circ$  to provide a smooth ride, allowing the operator to travel at speed over rough terrain and softening impact loads on structures and components. Large bore, low pressure cylinders are purpose designed for tough applications and offer a soft, smooth ride.

### Rear Suspension

Features a walking beam geometry with Caterpillar designed rear suspension mounts which provide a reliable and stable ride for excellent load retention.

### Automatic Traction Control

Fully Automatic Traction Control (ATC). Inter-Axle-Differential lock (IAD) and Cross-Axle-Differential locks (XAD) feature oil immersed clutches that require no operator input. Operation is seamless and smooth, and it eliminates wheel slip for maximum traction.

Sensors monitor the machine and wheel speeds, enabling instant response in low traction conditions.

Fully automatic, independent, IAD and XAD clutches are engaged on-the-go to optimize machine performance and control in all conditions. Clutches are automatically disengaged when ground conditions dictate, maximizing efficiency when steering or on uneven ground.

ATC eliminates wheel spin in soft under foot extreme ground conditions where little traction is available. It also reduces tire and driveline abuse eliminating lost efficiency caused by improper manual operation of the differential clutches.

### Retardation Control

The Cat engine compression brake control lever is positioned on the right-hand side of the steer column.

Four modes of operation with three steps of retardation, provide an optimum match between operating conditions and retarding power.

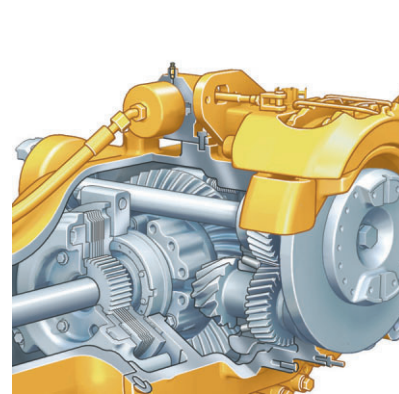



# Operator Comfort

High productivity from a comfortable, confident operator.

## **Ride Comfort**

The three-point front suspension with its oscillating axle and low-pressure ride struts, combined with the center-mounted cab, offers unrivaled levels of ride comfort for the operator in all driving conditions. The operator remains comfortable and productive throughout the day.

## **Spacious Two-Person Cab**

The 735B features a large two-person cab, offering comfortable working space for both the operator and passenger. The 735B, 740B and 740B EJ articulated trucks use the same spacious cab design.

## **Air Suspension Seat**

The air suspension seat enhances operator comfort with a cushioned upper high back, adjustable damping with three settings, ride zone indicator and adjustable lumbar settings. It is fully adjustable to provide the optimal driving position.

## **Passenger Seat**

Full-size passenger seat features a fully padded seat with a backrest and a wide, retractable seatbelt for a secure and comfortable ride. The passenger seat is positioned next to the operator seat, giving both the operator and passenger a clear view of the instrument panel, controls and the road.

## **Steering Column**

A comfortable driving position is provided by a telescopic and tilt adjustable steering column.



# Ease of Operation

Designed for ease of use – allows the operator to focus on production.

## Ergonomic Layout

The controls and layout of the cab are designed to make it as easy to operate as your car. Quick, easy to read and simple to operate, the controls and gauges on the 735B allow the operator to concentrate on production.

## Dash

The integrated wrap-around dash puts all controls within easy reach of the operator. Featuring LED illuminated rocker switches for the dash dimmer, rear wash wiper, hazard warning, head lamp, work lamp, heated mirrors (optional), diff-lock, secondary steer, heated seat (optional), machine security system (optional), A/C and cigar lighter. Color Multi-Purpose Display (CMPD) unit incorporating the messenger and rearview display. Provides an automotive feel with the industrial strength you would expect from Caterpillar.

## Color Multi Purpose Display (CMPD)

A multi screen display unit showing various levels of machine warning categories, performance and condition pages, including: Performance, Settings, Totals, Service, Machine Status, Operator, and Rearview Camera.

## Warning Categories

The monitoring system provides four warning categories.

The first warning category requires only operator awareness.

The second warning category requires a change in machine operation or maintenance to the system.

The third warning category requires an immediate change of the machine operation.

The fourth category requires the operator to immediately stop the machine. The fourth category also requires the operator to immediately shut down the engine.

## Viewing Area

The low sloping hood and placement of the cooling package behind the cab give the operator excellent all-around visibility. The large glass area and central operator position also provide excellent visibility.

## Transmission and Hoist Levers

The hoist lever provides easy, comfortable operation.

The transmission lever offers excellent comfort, and control for top gear limit, transmission hold and neutral lock.

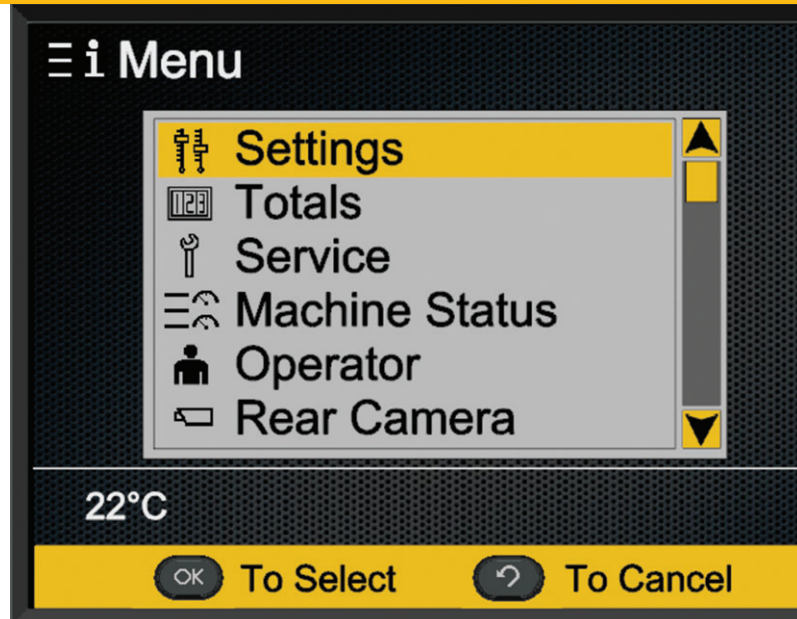

# Durability and Reliability

High machine availability maximizes productivity and lowers costs.

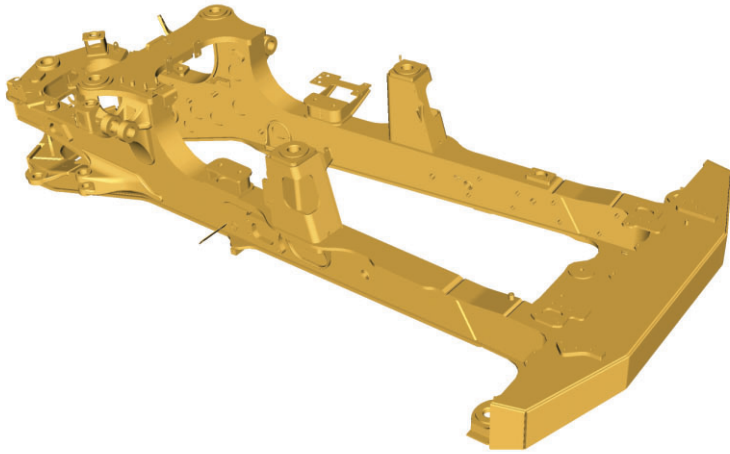

## Front Frame

The front frame design features a large box section and wide, stiff frame beams to handle torque loads. The divergent frame design decreases stress in the hitch area and optimizes suspension geometry. The frame design makes maximum use of robotic welding for increased durability.

## Rear Frame

Twin-box construction minimizes stress concentrations and provides low weight with long service life.

## Suspension

The three-point oscillating axle front suspension provides unparalleled ride quality. It also protects the truck from adverse road conditions by absorbing shock loads that would reach the frame.

## Articulating/Oscillating Hitch

The articulating hitch provides the truck with steering articulation, and the oscillation ensures all-wheel ground contact in rough terrain.

## Hitch Construction

Two-piece construction features a durable cast steel head bolted to a hard-wearing forged steel tube.

## Fast Hoist Cycle Times

Fast body raise and lower times mean less time spent in the dump area.

## Load-Carrying Capacity

The 735B has a large target area to provide consistently high load-carrying capacity. Its diverging flow design gives clean load ejection, which maximizes production and avoids the waste of material carry-back.

## Output Transfer Gear

Provides lubrication of all bearings and clutches using a distributed-pressure lubricated and filtered system.

## Enclosed, Oil-Cooled Brakes

High performance multi-plate, oil-immersed brakes are only required on front and center axles. These brakes provide outstanding stopping capability, while maintaining maximum durability and low wear characteristics.

## Parking Brake

Fitted to the center axle in an elevated position, spring applied and hydraulically released.

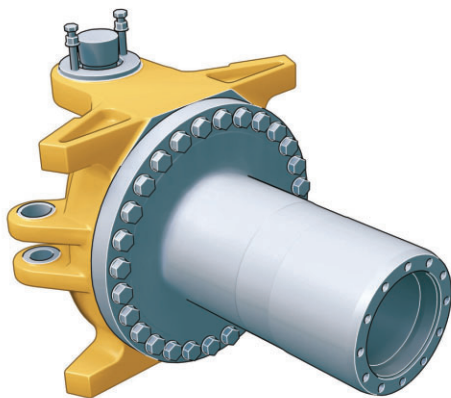
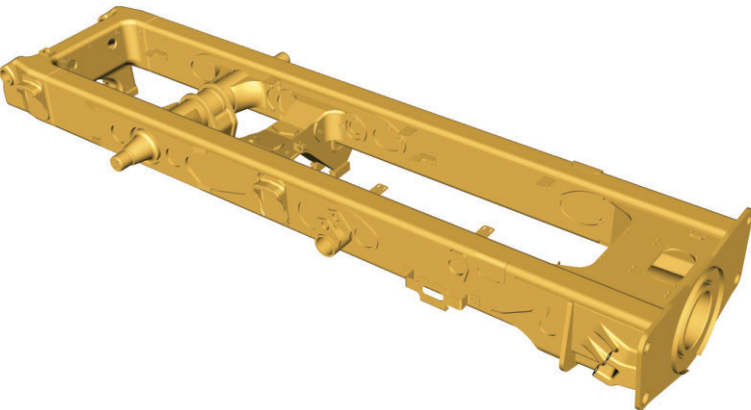



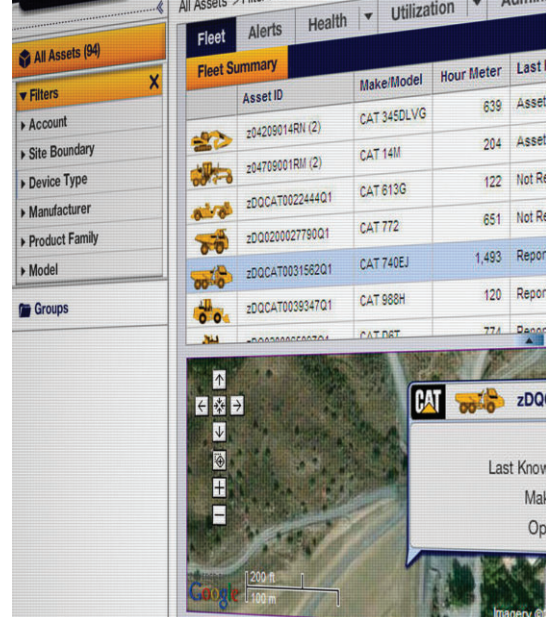

# Product Link

A secure and user-friendly application.

## Cat Product Link\*

Cat Product Link allows remote monitoring of the Articulated Truck to improve overall fleet-management effectiveness. Product Link is deeply integrated into machine systems. Events and diagnostic codes, as well as hours, fuel, idle time and other detailed information are transmitted to a secure web based application, VisionLink™. VisionLink includes powerful tools to convey information to users and dealers, including mapping, working/idle time, fuel level and more.

\* Product Link licensing not available in all areas. Please consult your Cat dealer for availability.

## Key Points

- See your entire fleet at a glance
- Monitor fuel usage
- Set up site boundaries and security alerts
- Click through to your Cat dealer for service and parts
- Customize the alerts and displays that matter to you
- Compare working time versus idle time
- Reduce owning and operating costs
- Get the right information to the right people at the right time
- Vital Information Maintenance System (VIMS™) upgrades available

## New Features

- Completely updated
- Robust new hardware
- Remarkably intuitive web-based interface
- Satellite and cellular coverage
- Open-system design for mixed-fleet use

# Serviceability

More time on production.

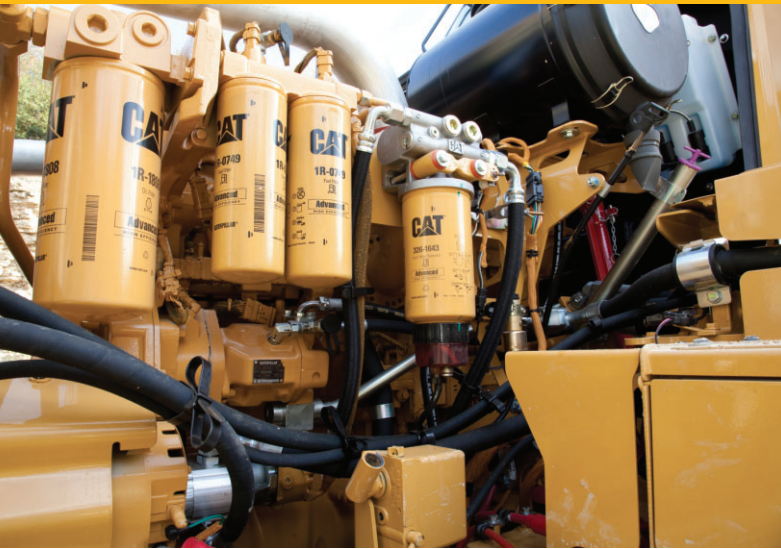

## Long Service Intervals

Long engine oil change and hydraulic oil change intervals reduce maintenance costs and downtime. Wheel-bearing adjustment is completely eliminated.

## Lubrication Points

Lubrication points are grouped at the rear of the front frame and the front of the rear frame. Universal joints are lubricated for life, eliminating servicing. Autolube is optional.

## Service Points

Engine and transmission dipstick and fill caps, air and fuel filters, and the fuel priming pump are all mounted on the left side of the engine under the electrically raised hood. Coolant level indicator and fill cap are outside the cab.

## Radiator

The radiator package is located behind the cab, which provides protection from frontal impacts and offers easy access to the inlet and outlet sides of the radiator. The Air To Air After Cooler (ATAAC) radiator is located at the front of the truck.

## Extended Life Coolant

Extends the change interval and improves component life by reducing aluminum corrosion.

## Electrical Service Center

Located inside the cab, this service center provides a power port, diagnostic connector and Cat Data Link connector.

## Cat Data Link Connector

The Cat Data Link connector provides a plug-in using a laptop computer with Electronic Technician (ET) software.

## Service Access

The cab tilts to the side to provide easy access underneath, which simplifies access to the transmission, drive shafts and hydraulic pumps. Machine electrical and hydraulic interfaces are located on the right side of the cab, behind a removable cab body panel for easy access.

## Truck Transport

The suspension system eliminates the need to lower the suspension when transporting the truck, reducing maintenance and downtime.





# Complete Customer Support

Cat<sup>®</sup> dealer services help you operate longer with lower costs.

## **Selection**

Make comparisons of the machines you are considering before you buy. Your Cat<sup>®</sup> dealer can help.

## **Purchase**

Consider the resale value, compare productivity and day-to-day operating costs and fuel consumption.

## **Operation**

For the best operating techniques to increase productivity and your profit, turn to your Cat dealer for the latest training literature and trained staff.

## **Maintenance**

Repair option programs guarantee the cost of repairs up front. Diagnostic programs such as S·O·S<sup>SM</sup> and Technical Analysis help you avoid unscheduled repairs.

## **Replacement**

Repair or rebuild? Your Cat dealer can help you evaluate the costs so you can make the right choice.

## **Product Support**

Your local Cat dealership will be with you every step of the way with its unsurpassed worldwide parts support, trained technicians and customer support agreements.

## **cat.com**

For more complete information on Cat products, dealer services and industry solutions, visit us on the Web at [www.cat.com](http://www.cat.com)

# Safety

Designed with safety as the first priority.



## Product Safety

Caterpillar has been and continues to be proactive in developing machines that meet or exceed safety standards. Safety is an integral part of all machines and system designs.

## Safety Features

- Cab integral ROPS (Roll Over Protection System) and FOPS (Falling Object Protection System)
- Rearview camera system provides a continuous panoramic rear view or when reverse gear is selected in the CMPD
- The secondary and parking brake functions are spring applied and hydraulically released
- Electro-hydraulic secondary steering system, automatically activates in forward/reverse or when stationary if low pressure is sensed. Can be manually selected for machine recovery purposes.
- External engine fuel cut off switch for easy access from outside of the machine
- External electrical system disconnect switch for easy access from outside of the machine
- Slip resistant surfaces – punched steel plate
- Hood raise and lower switch fitted at the LHS of dash which can only be accessed with the cab door open, for added security
- 75 mm (3 in) wide retractable seat belts for operator and passenger/trainee
- Cab roof mounted work lights (optional)
- Wide angled mirrors for excellent rear visibility
- Sweeping hood design for panoramic forward visibility
- Extensive hand rails
- Body raised alarm
- Heated motorized mirrors (optional)
- LED flashing beacon
- Wide positioned, front marker lights



# 735B Articulated Truck Specifications

## Engine

Engine Model	Cat® C15 ACERT™	
Gross Power – SAE J1995	336 kW	450 hp
Net Power – SAE J1349	326 kW	438 hp
Net Power – ISO 9249	330 kW	442 hp
Net Power – EEC 80/1269	330 kW	442 hp
Bore	137 mm	5.4 in
Stroke	171.5 mm	6.75 in
Displacement	15.2 L	926 in <sup>3</sup>

- The power ratings apply at rated speed of 1,800 rpm when tested under the conditions for the specified standard.
- The net power advertised is the power available at the flywheel when the engine is equipped with alternator, air cleaner, muffler and fan at minimum speed.
- Net power when the fan is at maximum speed is 296 kW (397 hp) per the SAE reference conditions.
- The 735B meets EPA Tier 2/EU Stage II emission specifications for U.S. and Europe through 2013.
- No engine derating required below 3650 m (12,000 ft).
- Peak engine torque gross (SAE J1995) 2312 N-m (1,705 lb-ft).
- Peak engine torque net (SAE J1349) 2264 N-m (1,670 lb-ft).
- Peak engine torque speed (rpm) 1,200.

## Weights

Rated Payload	32.7 tonnes	36 tons
---------------	-------------	---------

## Body Capacities

Heaped SAE 2:1	19.7 m <sup>3</sup>	25.8 yd <sup>3</sup>
Struck	14.7 m <sup>3</sup>	19.2 yd <sup>3</sup>
Tailgate Heaped SAE 2:1	20.9 m <sup>3</sup>	27.3 yd <sup>3</sup>
Tailgate Struck	15.2 m <sup>3</sup>	19.9 yd <sup>3</sup>

## Transmission

Forward 1	8.3 km/h	5.1 mph
Forward 2	11.3 km/h	7 mph
Forward 3	15.3 km/h	9.5 mph
Forward 4	20.6 km/h	12.8 mph
Forward 5	27.3 km/h	17 mph
Forward 6	37.7 km/h	23.4 mph
Forward 7	51.1 km/h	31.8 mph
Reverse 1	8 km/h	5 mph
Reverse 2	10.8 km/h	6.7 mph

## Sound Levels

Interior Cab	79 dB(A)
--------------	----------

- The operator sound exposure Leq (equivalent sound pressure level) measured according to the work cycle procedures specified in ANSI/SAE J1166 OCT 98 is 79 dB(A), for the cab offered by Caterpillar, when properly installed and maintained and tested with the doors and windows closed.
- Hearing protection may be needed when operating with an open operator station and cab (when not properly maintained or doors/windows open) for extended periods or in noisy environments.

## Operating Weights

Front Axle – Empty	19 716 kg	43,466 lb
Center Axle – Empty	6610 kg	14,573 lb
Rear Axle – Empty	5881 kg	12,965 lb
Total – Empty	32 206 kg	71,002 lb
Front Axle – Rated Load	3371 kg	7,432 lb
Center Axle – Rated Load	14 664 kg	32,329 lb
Rear Axle – Rated Load	14 664 kg	32,329 lb
Total – Rated Load	32 700 kg	72,091 lb
Front Axle – Loaded	23 087 kg	50,898 lb
Center Axle – Loaded	21 274 kg	46,901 lb
Rear Axle – Loaded	20 545 kg	45,294 lb
Total – Loaded	64 906 kg	143,093 lb

## Body Plate Thickness

Front	8 mm	0.31 in
Scow	16 mm	0.63 in
Side	12 mm	0.47 in
Base	16 mm	0.63 in

## Service Refill Capacities

Fuel Tank	565 L	149.3 gal
Cooling System	96 L	25.4 gal
Hydraulic System	330 L	87.2 gal
Engine Crankcase	40 L	10.6 gal
Transmission	85 L	22.5 gal
Final Drives/Differential	230 L	60.8 gal
Output Transfer Gear Box	22 L	5.8 gal

## Body Hoist

Raise time	11 Seconds
Lower time	7 Seconds

## Standards

Brakes	ISO 3450 – 1996
Cab/FOPS	ISO 3449 Level II – 2005
Cab/ROPS	ISO 3471 – 2008
Steering	ISO 5010 – 2007

# 735B Articulated Truck Specifications

## Dimensions

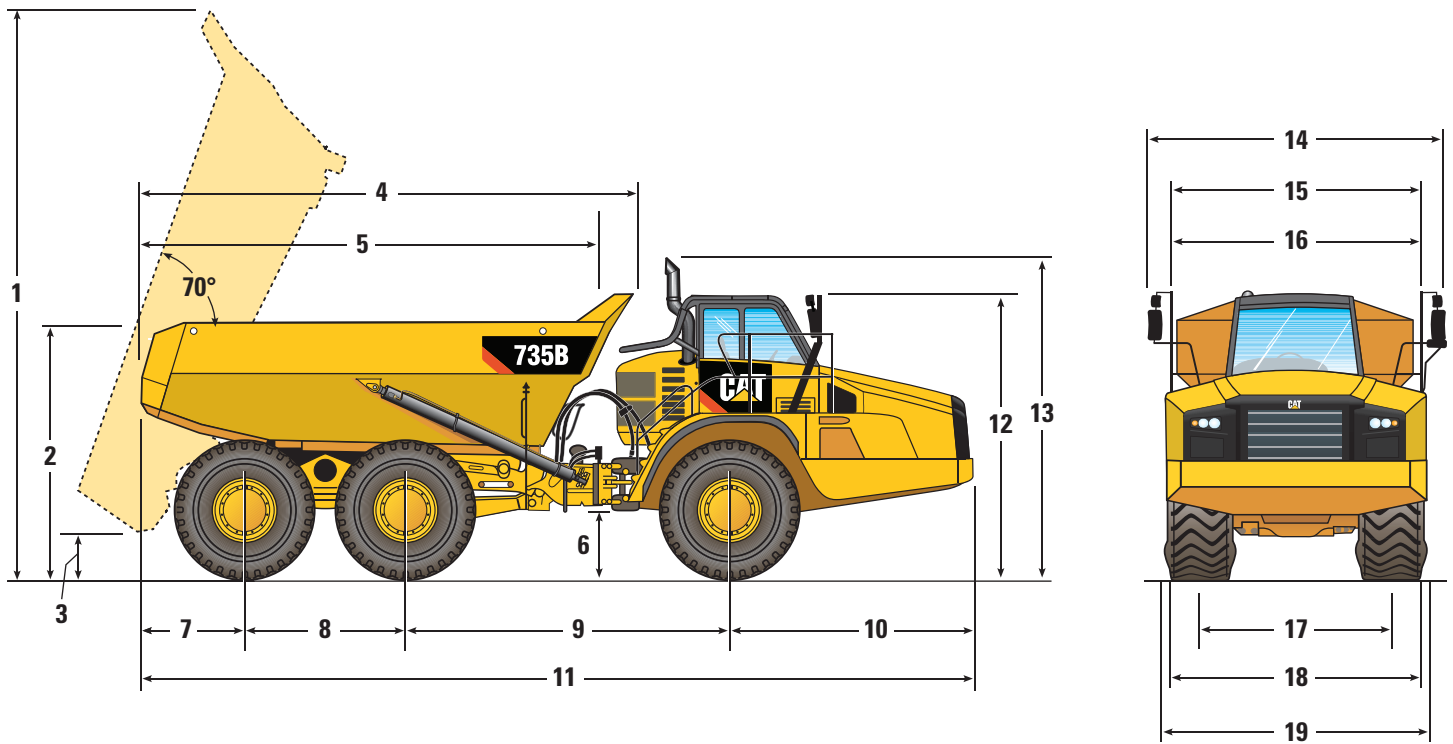

	mm	ft
<b>1</b>	6809	22.3
<b>2</b>	2982	9.8
<b>3</b>	635	2.0
<b>4</b>	6088	20.0
<b>5*</b>	5467	17.9
<b>6</b>	534	1.7
<b>7</b>	1458	4.7
<b>8</b>	1966	6.4
<b>9</b>	4246	13.9
<b>10</b>	3330	10.9

	mm	ft
<b>11</b>	11 000	36.1
<b>12</b>	3702	12.1
<b>13**</b>	3996	13.1
<b>14</b>	4160	13.6
<b>15***</b>	3690	12.1
<b>16</b>	3328	10.9
<b>17</b>	2687	8.8
<b>18</b>	3366	11.0
<b>19****</b>	3441	11.3

\*Inside of body.

\*\*Exhaust stack can be removed for transportation.

\*\*\*If equipped with a scissor tailgate.

\*\*\*\*Max-unladen over tire bulge.



## Turning Circle

Dimensions are for machines equipped with 26.5R25 tires.

### Turning dimensions

Steer angle – left/right	45°	
SAE turning radius	8138 mm	320.4 in
Clearance radius	8595 mm	338.4 in
Inside radius	4182 mm	164.7 in
Aisle width	5637 mm	221.9 in

## Steering

Lock to Lock

4.6 seconds @ 60 rpm

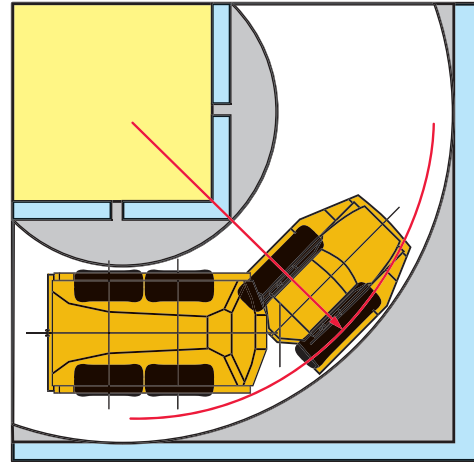

## Optimal Loader/Truck Pass Matching

Hydraulic Excavators	385C	365C	345D
Loader Capacity (Tonnes) – 50 min hr	954-1193	750-1100	665-805
Loader Capacity (Tons) – 50 min hr	1,049-1,314	825-1,210	735-885
Passes	3	4	5

Wheel Loaders	988H	980H	972H	966H	962H
Loader Capacity (Tonnes) – 50 min hr	565-790	590-650	490-565	400-535	325-400
Loader Capacity (Tons) – 50 min hr	625-870	650-715	540-625	440-590	360-440
Passes	3	3-4	4-5	5	6

An optimum system match gives you a major productivity advantage. The 735B is an excellent match for the Cat 385C, 365C and 345D Hydraulic Excavators; and Cat 962H, 966H, 972H, 980H and 988H Wheel Loaders. This results in increased production and lower system costs per unit of volume moved.

# 735B Articulated Truck Specifications

## Gradeability/Speed/Rimpull

To determine performance, read from Gross Weight down to % Total Resistance. Total Resistance equals actual % grade plus 1% for each 10 kg/metric ton (20 lb/ton) of Rolling Resistance. From this point, read horizontally to the curve with the highest attainable speed range. Then, go down to Maximum Speed. Usable Rimpull depends on traction available.

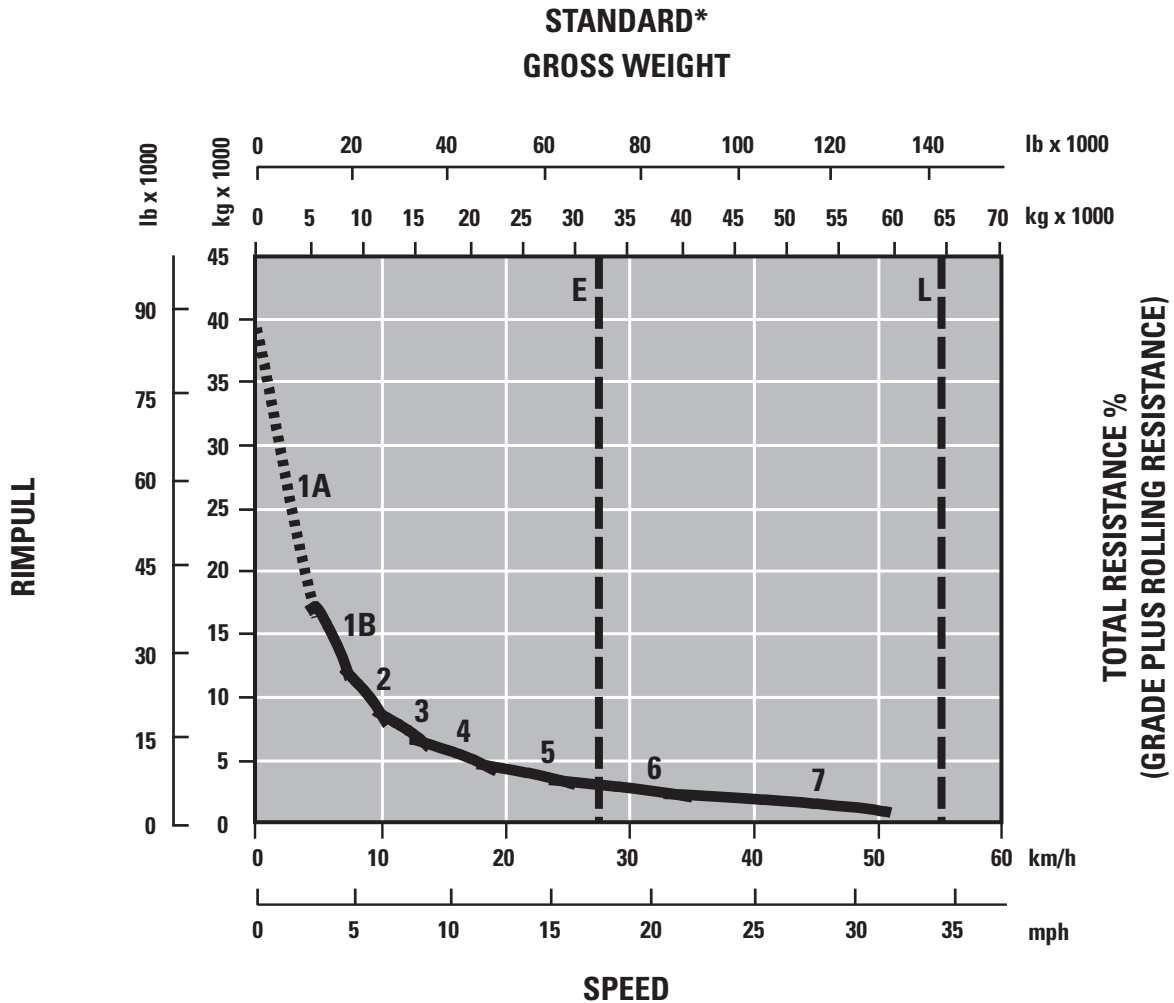

- 1A – 1st Gear (Converter Drive)
- 1B – 1st Gear (Direct Drive)
- 2 – 2nd Gear
- 3 – 3rd Gear
- 4 – 4th Gear
- 5 – 5th Gear
- 6 – 6th Gear
- 7 – 7th Gear

- E – Empty 32 206 kg (71,002 lb)
- L – Loaded 64 906 kg (143,093 lb)
- \* at sea level



## Retarding Performance

To determine performance, read from Gross Weight down to % Effective Grade. Effective Grade equals actual % favorable grade plus 1% for each 10 kg/metric ton (20 lb/ton) of Rolling Resistance. From this point, read horizontally to the curve with the highest attainable speed range. Then, go down to Maximum Speed. Retarding effect on these curves represents full application of the retarder.

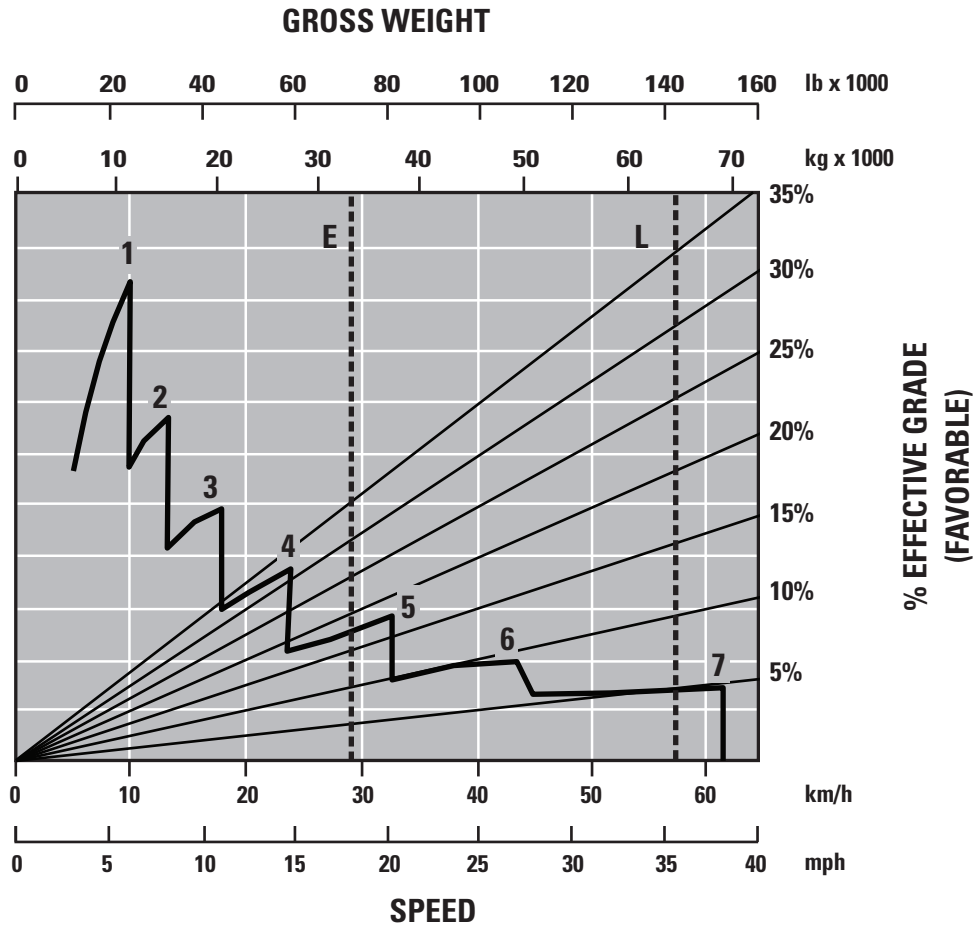

- 1 – 1st Gear
- 2 – 2nd Gear
- 3 – 3rd Gear
- 4 – 4th Gear
- 5 – 5th Gear
- 6 – 6th Gear
- 7 – 7th Gear

- E – Empty 32 206 kg (71,002 lb)
- L – Loaded 64 906 kg (143,093 lb)

# 735B Standard Equipment

Standard equipment may vary. Consult your Cat dealer for details.

Air conditioning with R134A refrigerant  
Air vents, adjustable  
Automatic Traction Control (ATC)  
Auto shift seven-speed forward and two-speed reverse transmission  
Back up alarm  
Body, adapted for exhaust heat  
Cat® C15 engine with ACERT™ Technology  
Color Multi-Purpose Display (CMPD) incorporating the Cycle Counter and rearview Camera Screen  
CD/Radio, heavy duty ready  
Differentials, standard with automatic clutched cross-axle and inter-axle differential locks for all axles  
Electrical system: 24 volt, 5A 24- to 12-volt converter  
Electro hydraulic hoist control  
Ether starting aid  
Glass windows, laminated and tinted, front  
Glass windows, toughened and tinted, sides and rear  
Guards: rear window, radiator, crankcase and axle  
Headlights, four  
Heater and defroster with four-speed fan  
Horn, electric

Lights: cab interior, front, side, rear, two reversing/working lights, two stop/tail lights, side width marker, front and rear direction indicators  
Mirrors, main and auxiliary, left and right  
Mud flaps, wheel arch and body mounted, with transportation tie backs  
Oil-cooled brakes, enclosed  
Operator and passenger grab hand rails  
Product Link  
Retarder, engine compression brake  
ROPS/FOPS cab, with full instrumentation, including:  
– Instrument cluster display module  
– Indicator lamps: left turn, secondary steering, primary steering loss, front and center axle brake temp (735B/740B and 740B Ejector only), brake oil pressure, action lamp, transmission fault, park brake, charging system status, differential lock fault, body not in float, right turn, high beam, transmission hold, machine filter warning, retarder, retarder up shift warning  
– Gauges: engine oil pressure, engine coolant temperature, torque converter oil temperature, fuel level, fuel tank level gauge

– LCD warnings/indicators: Gear, Alert, Speed, Soot, DPF Regeneration, Engine hours, Primary Steer, 2nd Steer, Machine Security (MSS), Retarder  
– Meters: service hour meter, speedometer, tachometer  
Seat, fully adjustable, air suspension  
Seat, padded passenger  
Secondary steering – electronic  
S·O·S<sup>SM</sup> sampling valves  
Spill guard, front, integral part of fabricated body  
Starting receptacle, electric, remote  
Storage – two cup holders, flask receptacle, under seat storage, door pocket, behind seat storage, coat hook  
Sun visor  
Three-axle, six wheel drive  
Tilt and telescopic steering wheel  
Tires, 26.5R25, radial  
Towing eyes, front and rear tow pin  
Two seat belts, retractable  
Vandalism protection: lockable caps for fuel tank and hydraulic oil tank  
Windows opening side, tinted  
Windshield wiper and washer, two speed, intermittent (front)  
Windshield wiper and washer, two speed, (rear)

# 735B Optional Equipment

Optional equipment may vary. Consult your Cat dealer for details.

Autolube installation for automatic greasing of bearings  
Body liners  
Cab roof mounted headlamps  
CD/Radio, heavy duty with auxiliary input  
Cold Weather Coolant (–51° C/–59.8° F)  
Cold weather start attachment

Engine Block Heater  
Exhaust heated body  
Extensions, fender  
Fast fuel fill  
Flashing LED Beacon  
Fuel Additive – Anti-Waxing  
Heated rearview motorized mirrors

Heated seats  
Product Link PL 321, PL 522 and PL 523 (where available)  
Long wheel base rear chassis (OEM)  
Machine Security System (MSS)  
Tailgate:  
– Scissor-type





# 735B Articulated Truck

For more complete information on Cat products, dealer services, and industry solutions, visit us on the web at [www.cat.com](http://www.cat.com)

© 2011 Caterpillar Inc.  
All rights reserved

Materials and specifications are subject to change without notice. Featured machines in photos may include additional equipment. See your Cat dealer for available options.

CAT, CATERPILLAR, SAFETY.CAT.COM, their respective logos, "Caterpillar Yellow" and the "Power Edge" trade dress, as well as corporate and product identity used herein, are trademarks of Caterpillar and may not be used without permission.

AEHQ6128 (4-2011)

